

Bottom Rail Deadbolt Swing Bolt

For Full Glass (Frameless) Doors

1830

ANSI/BHMA Type E8211 (Grade 1)

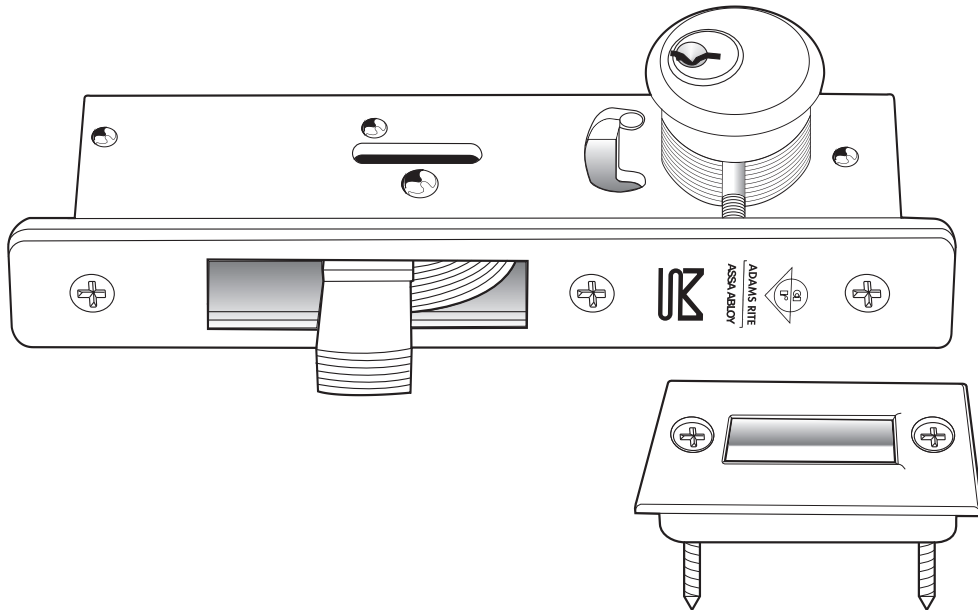

Cylinder Height (Backset)

31/32" and 1-1/8" only.

Case

Steel with corrosion-resistant plating. 1" x 6" x depth. (Depth varies with cylinder height. See table on back page.)

Function

For bottom rail locking of ultra-narrow stile or tempered glass doors whose bottom rail (shoe) is too shallow for the MS1861 (page SW-7). Mechanism is that of the MS1850A Deadbolt, but with the bolt size reduced. This keeps the threshold strike opening to a practical minimum, avoiding collection of debris or snagging of spike-heeled shoes. Armor faceplate protects cylinder setscrews from tampering and keeps them from loosening. Not applicable to wood doors.

Bolt

15/32" x 5/8" x 2-1/8" with 5/8" throw. Six ply laminated steel with eight plys within case. Center ply has Alumina-Ceramic core to deter hacksaw attack.

Strike

See back page for dimensions of strike slot which can be cut in metal thresholds. 4006 strike (shown) is optionally available, with stainless steel trimplate and plastic box.

Operation

360° turn of key or thumbturn throws or retracts the counterbalanced bolt. Key can be removed only when bolt is in a positively locked or unlocked position. Lock accepts any standard 1-5/32" mortise cylinder from either or both sides. Cylinder must have MS® cam. (See page SW-37.)



260 Santa Fe Street
Pomona, California 91767
(800) 872-3267 Fax:(800) 232-7329
www.adamsrite.com

Swing Bolt

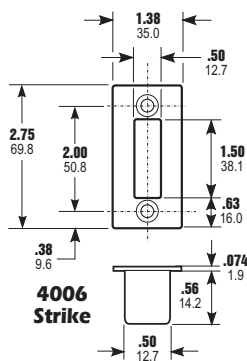
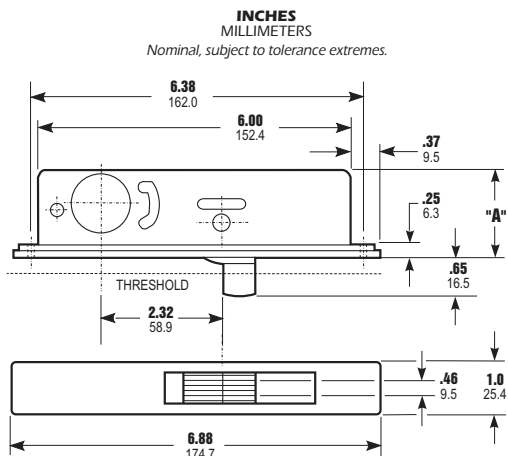

DASH NO.	CYLINDER HEIGHT	DIM. "A"
-02	31/32" 24.6	1.63 41.4
-03	1-1/8" 28.6	1.78 45.2

Cylinder Cam

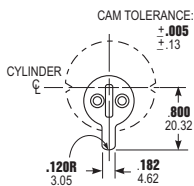

1830 deadbolts are operable by any standard 1-5/32" diameter mortise cylinder with special MS® cam dimensioned as shown. Cylinders with MS® cams can be readily obtained from most cylinder manufacturers. See page SW-37 for cylinder make and trim ring information.

Specify quantity and the following information.
Order related hardware separately.

Dash No.
Specify for lock depth
and cylinder height
according to chart above

Finish
Clear Anodized

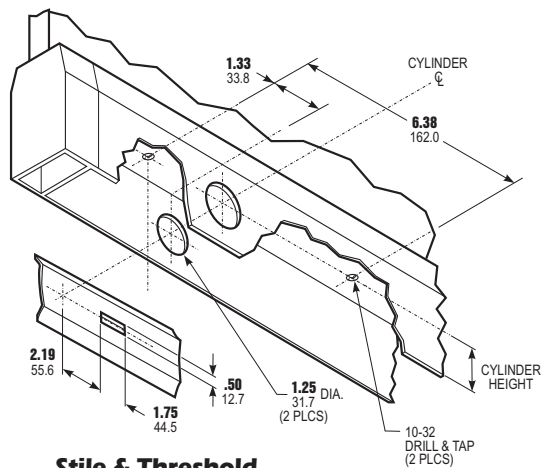

Stile & Threshold Preparation

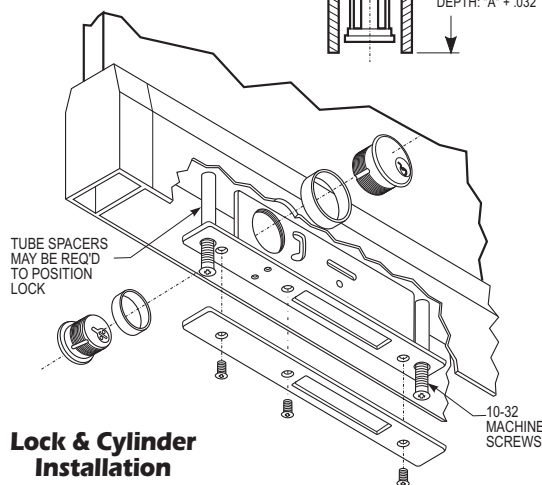
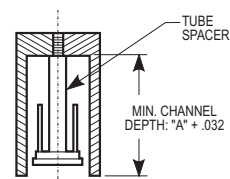

Lock & Cylinder Installation

Specify either 31/32" or 1-1/8" cylinder height. Order 4006 strike and cylinder(s) separately if required.

1830 - 02 - 628

Faceplate available in 628 Clear Anodized only.
Specify 4006 Strike separately if required.

Individually boxed with machine screws for mounting. Cylinders and/or thumbturn available at extra cost. Shipping weight: 1-1/2 lbs.